

MOUNTING, OPERATING, TESTING & MAINTENANCE INSTRUCTIONS FOR ROTEX 3/2 DIRECT ACTING ON/OFF/REGULATING NAMUR SOLENOID VALVE MODEL 30138, 30138LW

ROTEX retains all rights to this publication.

All details within this manual and the catalogue are subject to change without manner.

ROTEX will not be responsible for any damage whatsoever arising from the use of the Solenoid Valve, due to misuse or incorrect installation or misinterpretation of the information contained herein.

CONNECTION

VALVE TYPE	IN	OUTLET	OUTLET	EXHAUST
30138, 30138LW	1	2	4	3

(A) OPERATING PRINCIPLE

In De-energized condition of the solenoid A and B, applied the pressure at inlet port # 1, media pressure passed up to the Duse hole, which is blocked by plunger assembly, a part of media drawn through the pilot passage of the plunger assembly and support to plunger spring to moves downwards. In this state, Inlet port # 1 and Outlet port # 2 is disconnected. Outlet port # 2 and Exhaust port # 3 is connected. Media cannot come out.

In energized condition of the solenoid of the Solenoid A, plunger moves up and, thus applies the pressure at Inlet port # 1, above the plunger assembly pressure released from exhaust port # 3. In this state Inlet port # 1 and Outlet port # 2 is connected. Outlet port # 2 and Exhaust port #3 is disconnected.

Now to hold the pressure in actuator, energized the solenoid B and de-energized the solenoid A. To release the pressure from actuator de-energized the solenoid B. Actuator's spring side pressure released from port no. 4.

Solenoid B

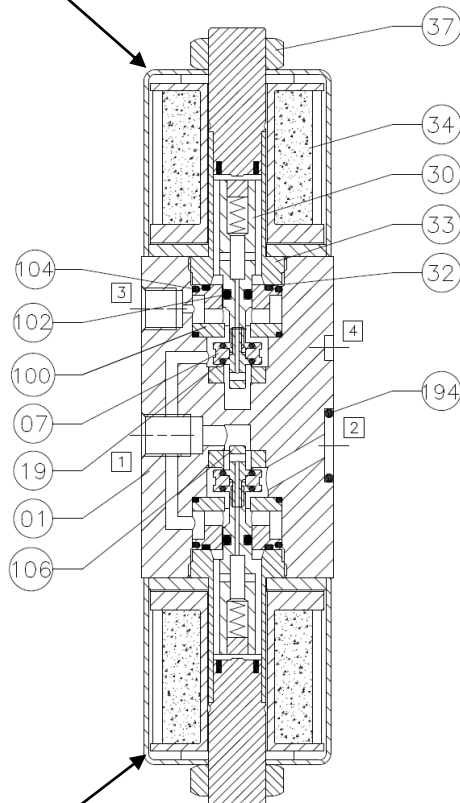

Solenoid A

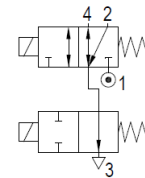

01	MANIFOLD 'O' RING	194
02	M HOLDER	106
04	SLEEVE 'O' RING	104
02	PLUNGER 'O' RING	102
02	SLEEVE	100
02	NUT	37
02	COIL ASSLY.	34
02	GUIDE ASSLY.	33
02	GUIDE 'O' RING	32
02	PLUNGER ASSLY.	30
04	SEAT 'O' RING	19
02	PRESSURE PLATE(VENTILTELLER)	07
01	BODY (GEHAUSE)	01
QTY.	DESCRIPTION	POS.No.

SPECIFICATION OF THE SOLENOID VALVE

- ⚠ NOTE :** 1) FOR “AC” (50 Hz & 60Hz) VOLTAGE, SELECT SOLENOID WITH “FR” OPTION.
 2) INTRINSICALLY SAFE SOLENOID CANNOT BE SUPPLIED WITH VALVE

IDENTIFICATION ON THE SOLENOID VALVE

a) VALVE MARKING

Marking on the **ROTEX** Solenoid Valve shows the following details:

(1)	Logo + Name & address of the Manufacturer
(2)	Valve Type / Code 30138 = Valve Model Suffix = Nil 5 = Orifice Ø 2R = Port Connection B5 = Body Material S2 = Seal Material
(3)	Work Order reference / Sr. No. of the Valve
(4)	Operating Pressure
(5)	Month & Year of manufacture
(6)	Valve Symbol
(7)	Media

b) SOLENOID MARKING

(1)	Logo + Name of the Manufacturer
(2)	Solenoid Type III = Solenoid Size III 24V = Solenoid Voltage DC = Solenoid Current 25 = Solenoid Construction H = Solenoid Class H Insulation
(3)	Work order No. Manufacturing Month / Year

⚠ NOTE: The product without Marking is out of warranty and risk.

c) PORT IDENTIFICATION

A solenoid Valve with NPT (F) threading is normally marked “N” near the port and with Metric threads are marked “M”. For ports with BSP threads, there is no marking.

d) Voltage, current & other details are additionally marked/ punched on the solenoid.

B) MOUNTING/INSTALLATION PROCEDURE:









1. ENSURE THAT:

- a) While storing, keep the valve in cool, dry, dust free area.
- b) On receipt of the valve, in case if the same is to be removed from the sealed plastic bag for inspection/testing, put them back with dust plugs on its ports and sealing the plastic bag as soon as the inspection/testing is over.
- c) The valve should be removed from its card board and/or plastic bag just before the installation.
- d) Flush lines before installing the valve.
- e) To avoid pressure drop and to achieve optimum parameters, Pipe / Tube / Fitting from the source of pressure to the valve and to the connected equipment should have ID which is ≥ NW (Orifice) of the valve.
- f) To avoid pressure drop, if more than one valve is being operated simultaneously from a common header, then minimum ID of the header can be calculated as under.







$$\text{ID Header} = \sqrt{(\text{NW}^2 \times n)}$$

n = Number of Valves operating at a time and which are connected to a common header,
NW = Orifice of the Valve.

-  g) Incorporate filter in the line to avoid hard particles entering into the valve.
-  h) The valve should be installed for the media for which it is intended for. This is to avoid the malfunction of seals and the valve. In case if you intend to use valve for media other than the one specified on that valve, check compatibility of media to Body Seal material and grease. Consult **ROTEX** in case if any doubt.
- i) Do not try to drill any additional holes or machine, modify any of the valve components.
- j) In case if the valve is used for dangerous fluid gas/liquid then, the user is hereby advised to maintain during operation and maintenance of the valve below LEL or above UEL to avoid explosion due to internal spark as the valves have not been assessed for the same.
- k) Inlet pressure does not exceed rated pressure.
- l) Hemp-Filaments, 'Jute' or even Teflon-Ribbons are normally not required, as the port connections of ROTEX Valve is accurately machined.
- m) To avoid over lap of the Teflon ribbon or cuts generated while tightening, getting carried away into the valve. Do not cover first two thread pitches with Teflon tape or sealant.
-  n) **For Solenoid Valve to be installed in European Union, check the applicability for ATEX. Refer separate Instruction Manual for ATEX approved Solenoid Valve.**
-  2. Provide Dust Cap on the exhaust port or ensure that the valve is mounted such a way that dust particles / rain water / process fluid do not enter into the valve through exhaust port of the valve. You can connect bend pipe of ID \geq NW of the valve so that the exhaust port is not directly (straight) open into the atmosphere.
- 3. The process fluid etc.: do not fall on the valve body.
- 4. In case if the surrounding atmosphere has traces or some other substance other than Air, check its compatibility with the Body material of the valve, Solenoid enclosure & other exposed parts.
-  5. In case if the valve is installed in potentially hazardous area, check for the temperature class of the Solenoid to avoid explosion due to heated Solenoid / other components.
-  6. Provide fuse of proper rating to avoid excess current passing through the Solenoid and thereby avoiding over heating.
-  7. It is not likely however; the user is advised to protect the valve against lightening as the same is not assessed.
- 8. Check internal components (wetted) parts for its compatibility with fluid passing through the valve.
-  9. **It is recommended to replace all the Rubber Parts including Plunger Assembly (Repair Kit) in case if the valve is to be installed and put in service after 2 years from the date of manufacture.**
- 10. Connect Port-2 to activate port of Rotary Actuator / Cylinder / Control Valve.
- 11. In case if Actuator does not open / close when the valve is operated electrically / manually, verify the correct mounting of the valve probably Port-2 of the Solenoid Valve may not even match to the active port of Actuator / Control Valve. After disconnecting the air, open the valve and re fix the same after turning 180°.
- 12. To prevent accidental wrong fixing of the valve, the solenoid valve is provided with M5 x 10mm long Grub Screw (supplied loose), fix the same on one of the spare hole of the Actuator / Control Valve keeping 2-3mm projection and matching the location at which the counter hole in the solenoid valve body. After this, in case tries of fixing the valve in other direction, the same will not fit well.

ELECTRICAL

- 1. Verify marking affixed on the Solenoid.
- 2. **For AC Voltage (50Hz or 60Hz), select solenoid with option "FR".**
- 3. Connect the power supply according to the voltage rating of the Solenoid
- 4. Ensure that the cover of Junction Box/Terminal Box is properly tightened wherever applicable.
-  5. Install valve in such a way that the rain water / other process fluid dripping along the cable does not fall on the SOV and has no possibility to run along the cable and enter into the Terminal area.
- 6. Fill in the space between cable and gland entry with a proper sealant. If necessary, you may mount the valve upside down or in any other direction.
- 7. Ensure that the Solenoid enclosure meets process and local authority requirement.
- 8. The Plug In, Terminal Box, FPJB, IS Solenoids are provided with test leads. Remove them before final installation.
-  9. Check for proper connections for the Solenoid which are polarity sensitive e.g. (a) Latched Solenoid.
-  10. **Refer separate manual for construction of the Solenoid and for specific instructions related to Solenoid e.g. (a) Latched Solenoid (b) EExd Solenoid IP 67.**
- 11. Ensure that the solenoid construction is selected properly meeting the environment in which the valve is supposed to be installed e.g. use of Exd solenoid for valve to be installed in hazardous location or Weatherproof Solenoid having IP 67 for outdoor installation.
-  12. **Flying Lead Solenoid is not recommended to be used for outdoor or indoor application where water/liquid splashing or high humidity is present.**
-  13. **Intrinsically Safe Solenoid can not be supplied with the Valve.**

TESTING OF THE VALVE AT THE TEST BENCH

 Check at least once in 3 years or following your routine maintenance schedule.

- a) Apply rated pressure at inlet port of the valve.
- b) Plug outlet port.
- c) Check operation of the valve and leakage at the exhaust ports and pilot vent at the rated and minimum working pressure by applying 75% to 120% rated voltage.
- d) Check the insulation resistance of the Solenoid by applying 500V DC at terminals and the solenoid housing. It should be more than 100 Mega Ohms.

RECOMMENDED SPARES



- a) Seal Kit (O Ring + Plunger Assembly).
- b) Spare Solenoid Kit.
- c) Repair Kit.

RECOMMENDED MAINTENANCE

- | | |
|--|--|
| • Replacement of Complete Set of O Ring | Once in 5 years or 2 million operations. |
| - Seat O Ring, Manifold O Ring,
- Guide O Ring, Anker o Ring,
- Sleeve O Ring, | |
| • Replacement of Plunger Assembly | Once in 5 years or 2 million operations |
| • Replacement of the Solenoid | As and when required. |
| • Check of Insulation Resistance, Resistance of the Solenoid... | Once in a year (should be ≥ 100 M Ohms @ 500VDC. |
| • Check Resistance of the Solenoid... .. | Replace Solenoid if the resistance reduces more than 5% computed at 20°C as compared to its Initial value. |

PREVENTIVE

MAINTENANCE – GENERAL INSTRUCTION

- The Solenoid Valve must be removed from the site and has to be maintained under safe conditions.
-  • All air and electrical connections must be switched off before removing valve from the line.
-  • It is recommended to replace complete set of O Ring even if one of the O Ring is damaged. This is to ensure trouble free operation of the valve and will avoid its premature failure.
- Using Grease other than Silicon base Molykote 55M will lead to premature failure of O Rings of the **ROTEX** Solenoid valve.
-  • If necessary to clean the components, **do not use Kerosene, Diesel, Petrol to clean valve as this damages the O Rings and other rubber material. Instead use light Detergent Soap Solution.**
- Ensure that the components are free from dust, dirt, lint and metal burrs.
- Twisting of O Ring should be avoided. Ensure that the twist is removed before fitting matching part.
- While closing the matching part, the matching part should be pushed in a straight line. Turning motion should be avoided.
- Pinching of O Ring at the groove corner at the time of closing gland should be avoided.
- User is requested to use safe practice for maintenance.
- It is important to place the dismantled Valve Parts on a clean paper or cloth in same sequence in which you have dismantled them.
- Ensure to keep all the components of the valve separately to avoid their mixing up. The component appears to be same may have small differences which will cause malfunction if interchanged.
- In case of difficulty you should contact the Agent, Distributor or **ROTEX** directly.
- Using **ROTEX** genuine spares will **guarantee** you trouble free operation and will avoid premature failure.

(A) TO REPLACE SOLENOID

- 1) Open dome nut and pull out solenoid
- 2) Replace new solenoid ensuring the construction, voltage and current meets the requirements.
- 3) Tighten the dome nut applying torque of 0.2 kgm to 0.35 kgm to avoid over tightening of the solenoid.
- 4) Measure and record resistance of the Solenoid.

(B) TO REPLACE GUIDE ASSEMBLY (CORE TUBE) / PLUNGER, SET OF 'O' RING

- 1) Open dome nut and pull out solenoid.
- 2) Open Guide Assembly (Core Tube) using guide opening tool / spanner.
- 3) Pull out Plunger Assembly along with Sleeve and ventilteller.
- 4) Insert a small pin in the hole of magnet holder and second pin in the Plunger.
- 5) Open the same by rotating anti clockwise. Remove old 'O' Rings and clean metallic parts.

- 6) Replace all the 'O' Rings like Plunger O Ring, Seat O Ring and reassemble magnet holder into the Plunger using small amount of Loctite 542 on the thread of magnet holder .
- 7) Reassemble Sleeve along with Sleeve O Ring and insert assembly in the body.
- 8) Fix the Guide Assembly ensuring that Guide O Ring and Sleeve O Ring are well placed.
- 9) Check the valve for operation and leakage.

STORING, CLEANING AND MOUNTING OF ELASTOMERS: SYNTHETIC RUBBER PRODUCTS

- Store Plunger, O Ring Set in sealed polyethylene bag, kept in cool, dry, dust free area and avoid direct contact with all light sources emitting ultra violet rays, or contact with fumes, solvents, fuels, lubricants, chemicals, acids, disinfectants.
- Follow Maintenance General Instruction & specific procedures to replace O Ring set as listed above.



Guide Opening Tool
Photo - 1

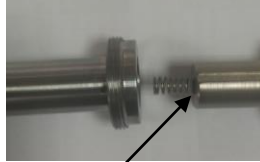

Flat Face this side
Photo - 2



Plunger with sleeve
Photo - 3

Contact:

ROTEX AUTOMATION LIMITED

987/11, GIDC, MAKARPURA, VADODARA – 390010, INDIA

Tel.: +91 265 2638136, 2638746, 2638795 Fax: +91 265 2638130

E-mail: rotexbrd@rotexautomation.com

Website: www.rotexautomation.com